

Floor Drains with Integral Traps

WADE

1120CONH Cast iron floor drain with integral trap, spigot side outlet, floor level cleanout, integral clamping collar, seepage openings, 1/2" plugged primer tap and _____" dia. nickel bronze strainer with vandal proof screws.

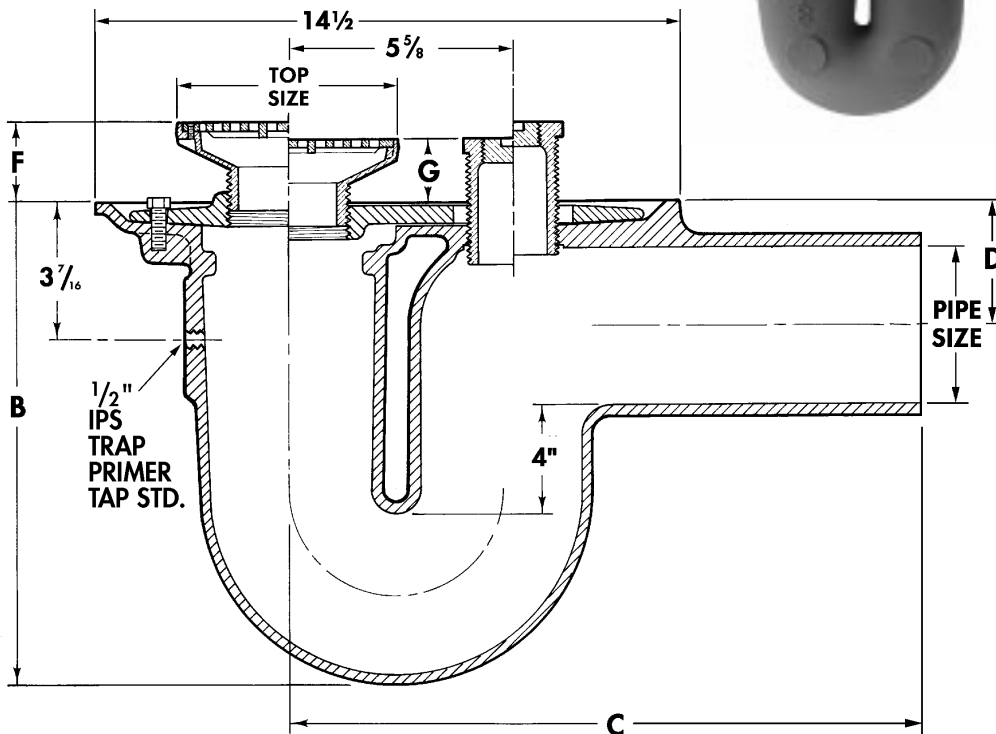

Cat. No.	Pipe Size	Top Size	ANSI* Load Class	Flow Rate (GPM)	Free Area Sq. In.	Wt. Lbs.	B	C		F		G	
								Spigot	D	Min.	Max.	Min.	Max.
1122CO,STD5	2	5	L.D.	14	5.8	41	10	15 3/4	3	1 3/8	2 1/8	7/8	1 1/2
1122CO,STD6	2	6	L.D.	21	7.7	42	10	15 3/4	3	1 5/8	2 1/4	1	1 5/8
1122CO,STD7	2	7	L.D.	20	10.6	43	10	15 3/4	3	1 5/8	2 1/8	1	1 1/2
1123CO,STD5	3	5	L.D.	27	5.8	41	10	16	2 3/4	1 3/8	2 1/8	3/4	1 1/2
1123CO,STD6	3	6	L.D.	33	7.7	42	10	16	2 3/4	1 3/8	2 1/4	1	1 5/8
1123CO,STD7	3	7	L.D.	40	10.6	43	10	16	2 3/4	1 5/8	2 1/8	1	1 1/2
1124CO,STD6	4	6	L.D.	33	7.7	43	12	17 1/4	3	1 5/8	2 1/4	1	1 5/8
1124CO,STD7	4	7	L.D.	43	10.6	44	12	17 1/4	3	1 5/8	2 1/8	1	1 1/2
1124CO,STD8	4	8	L.D.	57	14.0	45	12	17 1/4	3	1 1/2	1 1/4	1	1 5/8

For optional strainers see pages 3-12, 3-15.

*L.D.= Light Duty (Under 2000 lbs.)

OPTIONS

Suffix	Description
27	Sediment Bucket
31	Backwater Valve
39	Galvanized Iron Parts
94	Extension Adaptor
94	Extension Adaptor, Galvanized
EF4	4" Dia. Funnel
EF6	6" Dia. Funnel
EG6	2 1/2 x 6 1/8" Elongated Funnel (NB Only)
EG8	3 1/2 x 8 1/4" Elongated Funnel (Type EG Requires 6" Dia. Strainer Min.)

OPTIONAL STRAINERS (ADD SUFFIX TO CAT. NO.)

Suffix No.	Sizes Available
AX	6" Dia.
D	6" Dia.
ER	5", 7" Dia.
F	6" Dia.
G	5x5, 6x6
H	4x8, 5x12
K	6" Dia.
TS	7" Dia.
WD	2x6

OUTLETS

(NH) No-Hub