

AM1 Flush Valve Support

(Mounts to an upper carrier fixture stud and secures water supply piping to flush valve, during and after construction.)

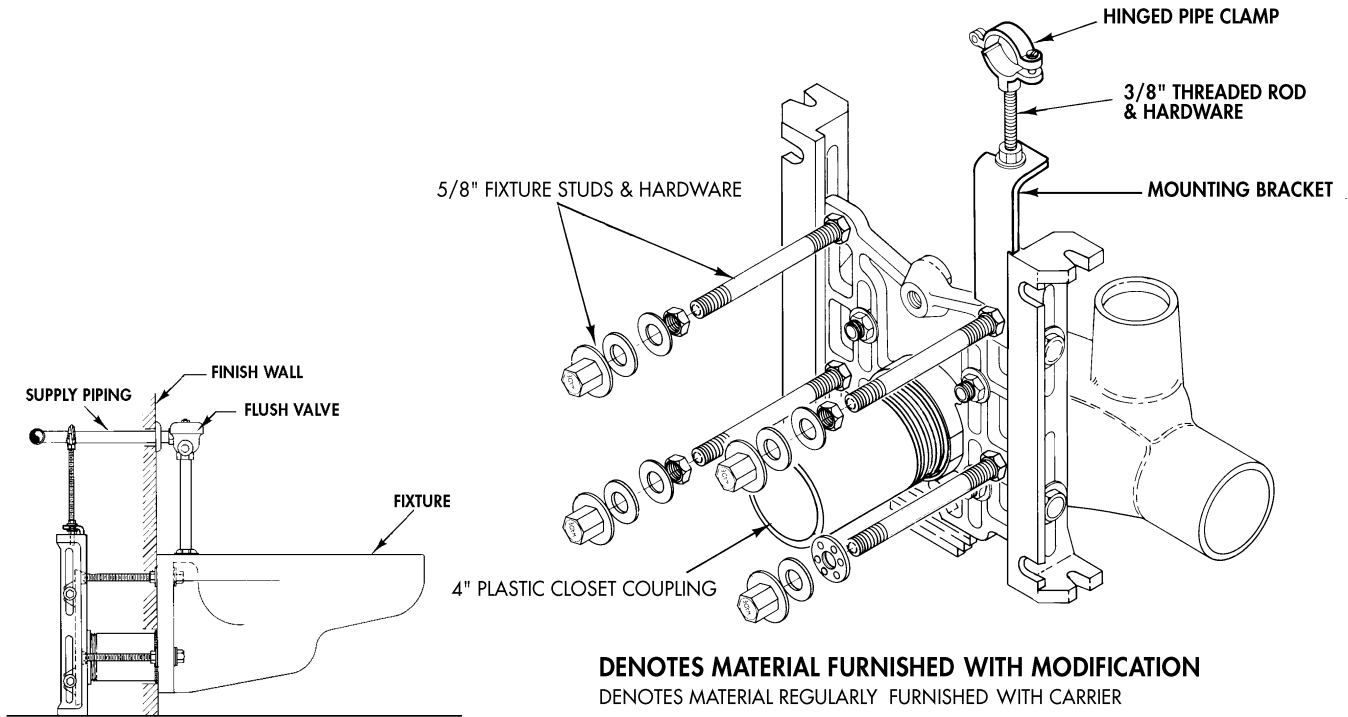

M3 Vandal Proof Hardware

Designed to prevent casual damage to fixture. (Installed with special socket wrench.)

